

3D Printer Filament Holder

User Manual



Read this manual carefully and completely, and retain for future reference.

WARNINGS & CAUTIONS

- Before installation, check all parts according to the parts list and verify whether the parts are complete. Contact us if you have any questions.
- Assemble the product in the correct order as instructed in this manual.

PARTS LIST

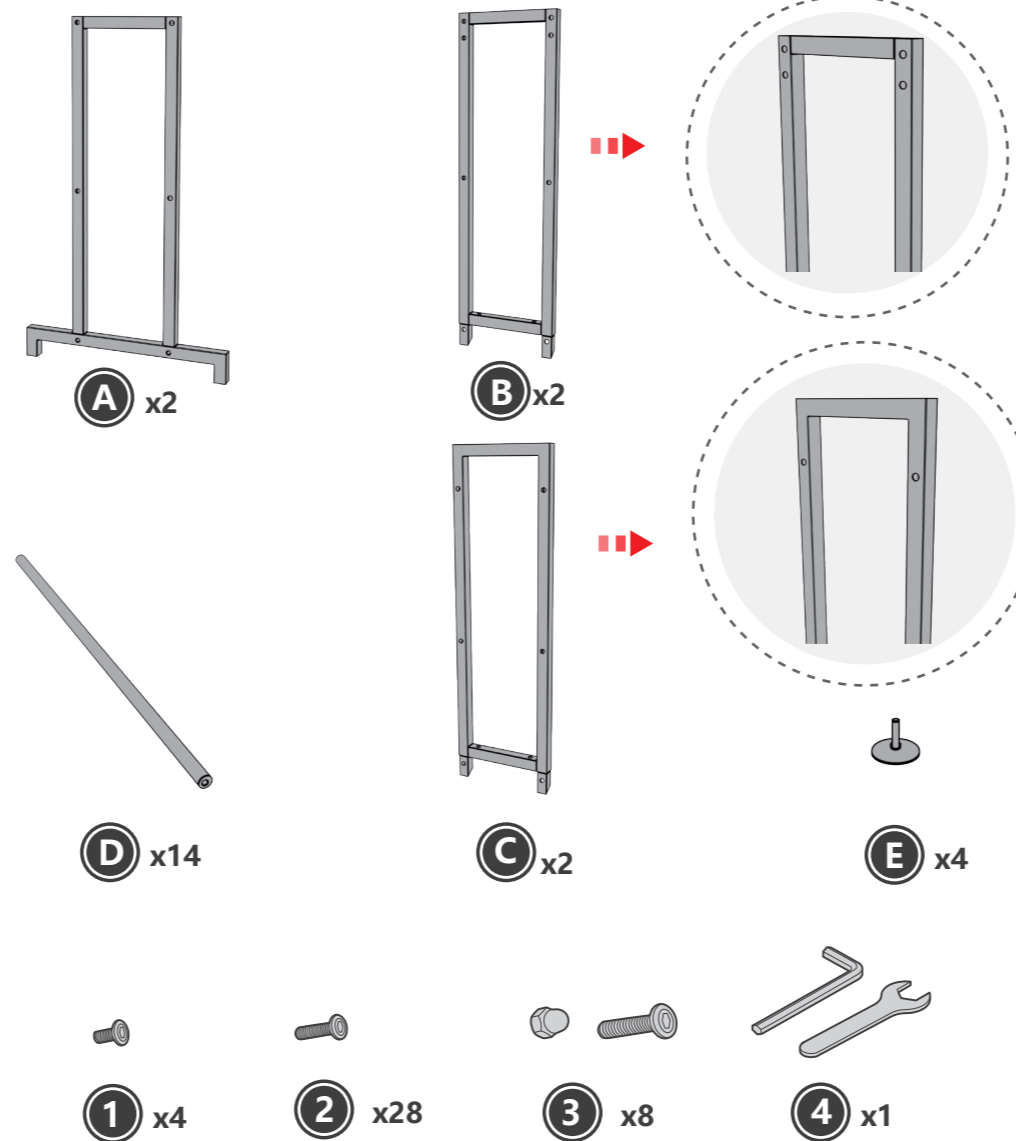

INSTALLATION STEPS

STEP 1

Align Components A and B, and then secure them using Screw ③.

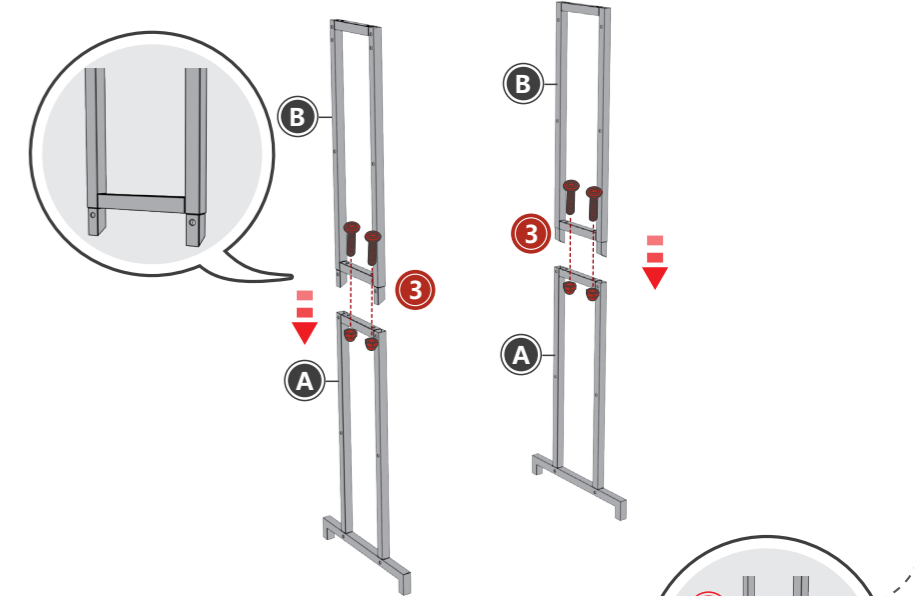

STEP 2

Connect the assembled AB components from Step 1 to Component C, and fasten them with Screw ③.

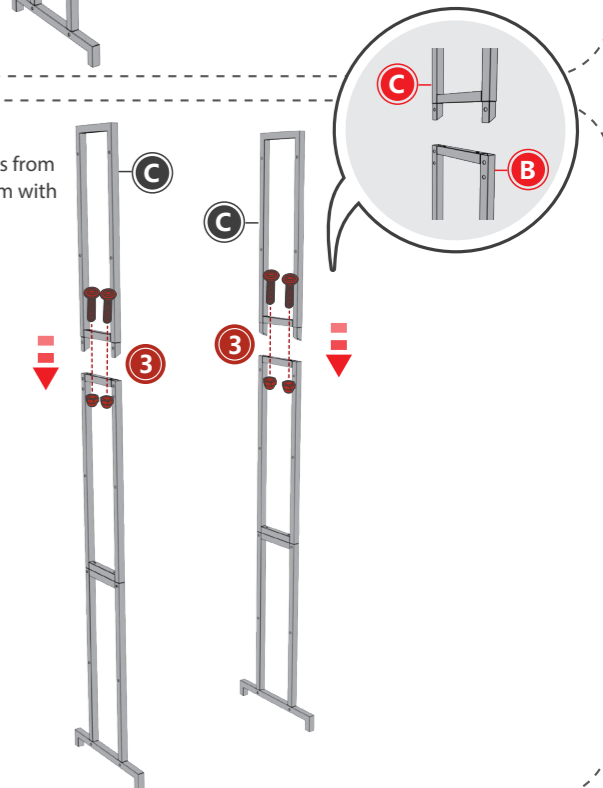

STEP 3

Use screws ① to secure B and C.
Then, tighten Component D with screws ②.

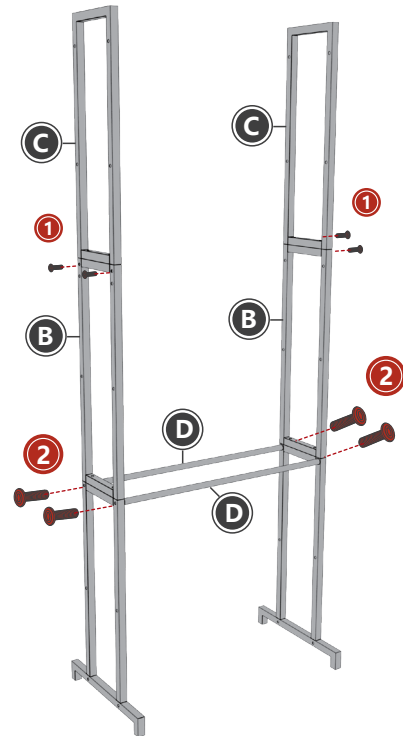

STEP 4

Insert Component D from bottom up
following the arrow.
Fix them with Screw ②.

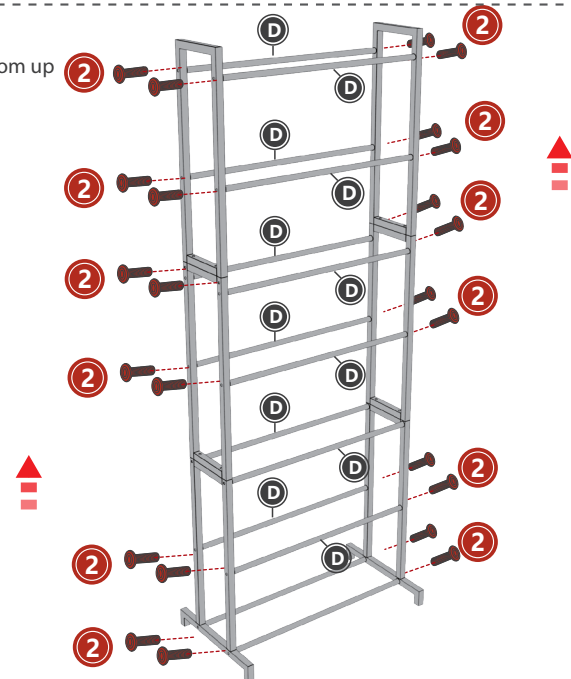

STEP 5

Install Component E. Adjust to a proper height and ensure the rack is stable.



WARRANTY AND SERVICE

Our commitment to you doesn't end with the purchase. If you encounter any issues or have questions about our products, feel free to contact our dedicated customer service team. We are here to help and will go the extra mile to ensure your satisfaction. Your happiness is our priority, and we'll work tirelessly to resolve any problems you may encounter. Don't hesitate to reach out; we are always ready to assist you.

POKIPO